

AQS3624 2.5G Ethernet Switch

24x 2.5GT + 6x SFP+ Switch

Cost Effectiveness 2.5G L3 Management Switch

"In between 1 Gigabit and 10 Gigabit, there is still a lot of space"

With the development of access technologies, as well as the need for applications, a various 2.5G equipment like home motherboards and enterprise PCs are using 2.5G network cards, Gigabit switches are not enough to cope but 10 Gigabit switches are costly. A 2.5G switch is actually an inevitable choice for many users.

The small scale 2.5G switch market for household application has emerged but is not much. Our AQS3624, a 24-port 2.5G Ethernet switch, is a cost effective solution for industrial and SME.

Application scenes like the convergence of broadband access networks, such as XGPON, Wi-Fi 6, 5G base stations and some application scenarios of local area networks include the network of NAS servers and 2.5G networking.

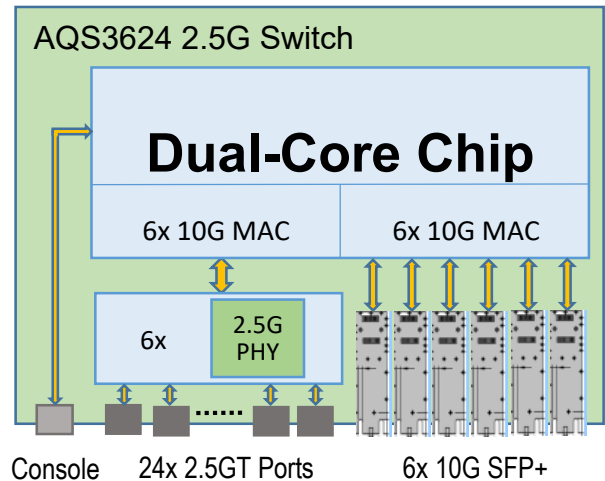

Figure 1. AQS3624, Block Diagram

- 24x 2.5G ports, backward compatible with 1000Mbps
- 6x 10G optical uplink ports
- efficient forwarding, high speed and traffic stabilization
- Support L3 network management functions
- Support uplink convergence
- Low power consumption and power saving mode
- Cost effective

Product Highlights

Port Capacity

Our AQS3624 switch is designed with a non-Euro-American switching chip with a specific 2.5G PHY, allowing it to provide 24 2.5Gbps Ethernet ports and 6 10G optical ports upstream.

Cost-Effective Chipset Solution

The switching chipsets used of our AQS3624 switch provide a cost-effective and powerful solution. The switch chip uses the memory forwarding mechanism, the internal integration of high-capacity memory, with 120Gbps transfer bandwidth, can provide 240Gbps exchange capacity, so that all ports can achieve 2.5Gbps non-blocking speed transmission. It has low power consumption, small packaging, multiple interfaces, covering a variety of application needs. Our AQS3624 switch provides 24 2.5G platform speed performance suitable for small and medium-sized enterprises and operators access or edge applications, providing a cost-effective solution, is the best choice for 2.5G Ethernet switch.

Plug-and-Play

The 2.5G ports of our AQS3624 switch are using adaptive mode, backward compatible with 10M/100M/1000Mbps standard RJ45 port. It is simply plug and play with the original Cat 5e cable to upgrade to 2.5G fast speed network. It adopts storage forwarding mechanism, internal integrated high-capacity storage, can ensure that all ports can achieve non-blocking speed transmission, adapt to more unexpected situations.

L3 Management and Diversified Management Features

In addition to the common L3 layer management, our AQS3624 switch can enhance to support some diversified management features like stack management, DHCP Server, uplink convergence, cloud management, network time synchronization, etc. We can also base on your software feature requirement to develop your specific switch for your own use.

Customization Service and Existing Models

Our company has the technical and engineering abilities to develop a new switching product in both hardware and software aspect. We can also base on customer requirements, specific industries or application scenarios, to design the unique specifications and requirements of our customers' own products.

Existing Model Port Specification	AQS3624	AQS3432	AQS3240	AQS3248
2.5G Base-T	24	32	40	48
10G SFP+	6	4	2	2



AQS3624 24x 2.5GT Switch

Hardware Specifications

Item (AQS3624)	Details
Ethernet Port	24x 10M/100M/1G/2.5G Base-T RJ45
Optical Port	6x 10G SFP+
Control Port	1x RJ45-R232 Serial Interface (115200,8,N,1)
Power	1x AC 100~240V 50/60Hz
Power Consumption	30W
Standard	IEEE802.3, IEEE802.3u, IEEE802.3ab, IEEE802.3Z, IEEE802.3X, IEEE802.1Q, IEEE802.1p, IEEE802.3ab, IEEE802.1D, IEEE802.1X
Switching Capacity	240Gbps / non-blocking
Switching Mode	Store-and-Forward
Packet Buffer	16Mbit
MAC Address Table	32K-entry
Jumbo Frame	12KB
Storage Conditions	Storage Temperature : -10 ~ 85°C
Operating Conditions	Operating Temperature : 0 ~ 70°C

Software Specifications

Status	Feature List
<input checked="" type="checkbox"/>	IP, MAC, Port, VLAN Binding Combinations
<input checked="" type="checkbox"/>	802.1p priority
<input checked="" type="checkbox"/>	VLAN
<input checked="" type="checkbox"/>	IGMP Snooping
<input checked="" type="checkbox"/>	MLD Snooping
<input checked="" type="checkbox"/>	Multicast VLAN Registration (MVR)
<input checked="" type="checkbox"/>	QoS
<input checked="" type="checkbox"/>	ACL
<input checked="" type="checkbox"/>	IPV4 Static Route Setup
<input checked="" type="checkbox"/>	IPV4 Static Route Setup
<input checked="" type="checkbox"/>	DHCL Server, Client, Relay, DHCP Snooping